



#1

ANTARCTICA™

BIRKS
WHITE
ROBERTS



ANTARCTICA

SIMON BIRKS
WRITER

WILLI ROBERTS
ARTIST + COVER A

LYNDON WHITE
LETTERS + COVER B

ABIGAIL HARDING
SAN DIEGO COMIC-CON®
EXCLUSIVE VARIANT

DREW ZUCKER
RETAILER VARIANT

Hannah Curtis is a young girl whose life implodes the day her father fails to return from the secretive Smith-Petersen Research Station in Antarctica. After years of feeling lost, a friend helps Hannah get a job at the same station, little realising she's about to stumble headfirst into a conspiracy that threatens everything she's ever believed.

REACTIVATION

ELENA SALCEDO
EDITOR

VINCENT VALENTINE & PHIL SMITH
PRODUCTION



For Top Cow Productions, Inc.
Marc Silvestri - CEO
Matt Hawkins - President & COO
Elena Salcedo - Vice President of Operations
Vincent Valentine - Vice President of Production
Phil Smith - Design and Production
Lisa Y. Wu - Marketing Director
Want more info? Check out:
www.topcow.com
for news & exclusive merchandise!



IMAGE COMICS, INC. • Robert Kirkman: Chief Operating Officer • Erik Larsen: Chief Financial Officer • Todd McFarlane: President • Marc Silvestri: Chief Executive Officer • Jim Valentino: Vice President • Eric Stepterson: Publisher / Chief Creative Officer • Nicole Lapointe: Vice President of Science • Leanna Caunter: Accounting Analyst • Sile Korpela: Accounting & HR Manager • Matt Parkinson: Vice President of Sales & Publishing Planning • Lorelei Bunjes: Vice President of Digital Strategy • Dirk Wood: Vice President of International Sales & Licensing • Ryan Brewer: International Sales & Licensing Manager • Alex Cox: Director of Direct Market Sales • Chloé Ramos: Book Market & Library Sales Manager • Emilio Bautista: Digital Sales Coordinator • Jon Schaffman: Specialty Sales Coordinator • Kat Salazar: Vice President of PR & Marketing • Deanna Phelps: Marketing Design Manager • Drew Fitzgerald: Marketing Content Associate • Heather Doornink: Vice President of Production • Drew Gill: Art Director • Hilary D'Amore: Print Manager • Tricia Ramos: Traffic Manager • Melissa Gifford: Content Manager • Erika Schmatz: Senior Production Artist • Wesley Griffith: Production Artist • Rich Fowks: Production Artist • IMAGECOMICS.COM

ANTARCTICA #1, July 2023. First Printing. Published by Image Comics, Inc. Office of publication: PO BOX 14457, Portland, OR 97293. Copyright © 2023 Simon Birks and Top Cow Productions, Inc. All rights reserved. "ANTARCTICA" its logos, and the likenesses of all characters herein are trademarks of Simon Birks and Top Cow Productions, Inc., unless otherwise noted. "Image" and the Image Comics logos are registered trademarks of Image Comics, Inc. Comic-Con and the Comic-Con logo are registered trademarks of San Diego Comic Convention. No part of this publication may be reproduced or transmitted, in any form or by any means (except for short excerpts for journalistic or review purposes), without the express written permission of Simon Birks, Top Cow Productions, Inc., or Image Comics, Inc. All names, characters, events, and locales in this publication are entirely fictional. Any resemblance to actual persons (living or dead), events, or places, without satirical intent, is coincidental. Printed in the USA. For international rights, contact: matt@topcow.com.



To find the comic shop nearest you, call: 1-888-COMICBOOK



This is how I remember my father.



Walking through the rain, returning home from a tour somewhere tough and secret.



A father whose love stretched out all around him.



Enveloping everyone he was near.

But more importantly, enveloping me.





And even though I missed him when he went away...



I always looked forward to him coming back.



He wasn't the best father, but I could forgive him that.

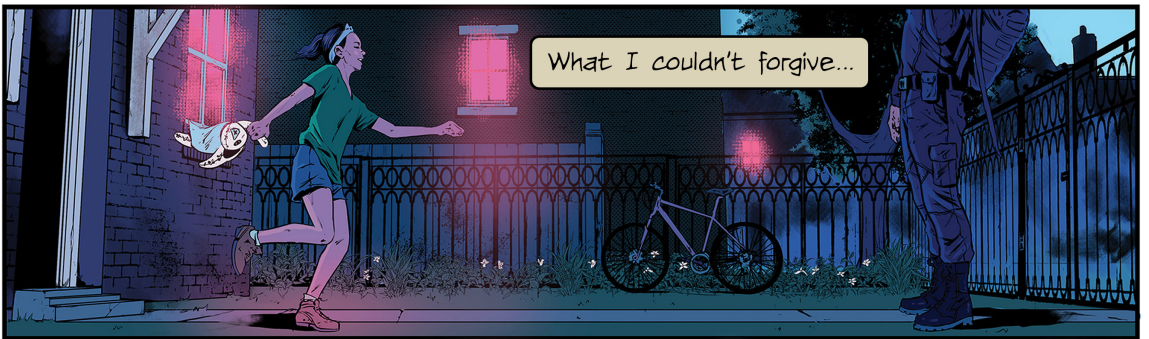

What I couldn't forgive...



...was him not coming back at all.



He was lost.

I was angry at him. Furious.

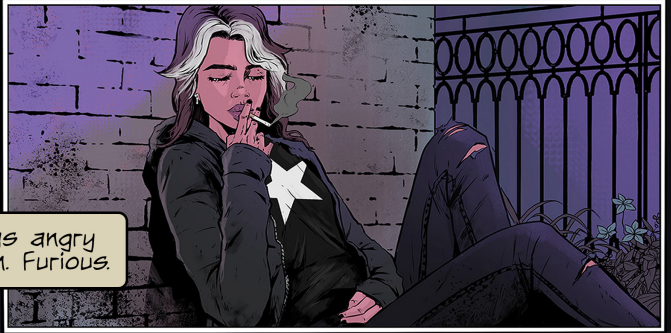

So angry, in fact, I didn't notice...

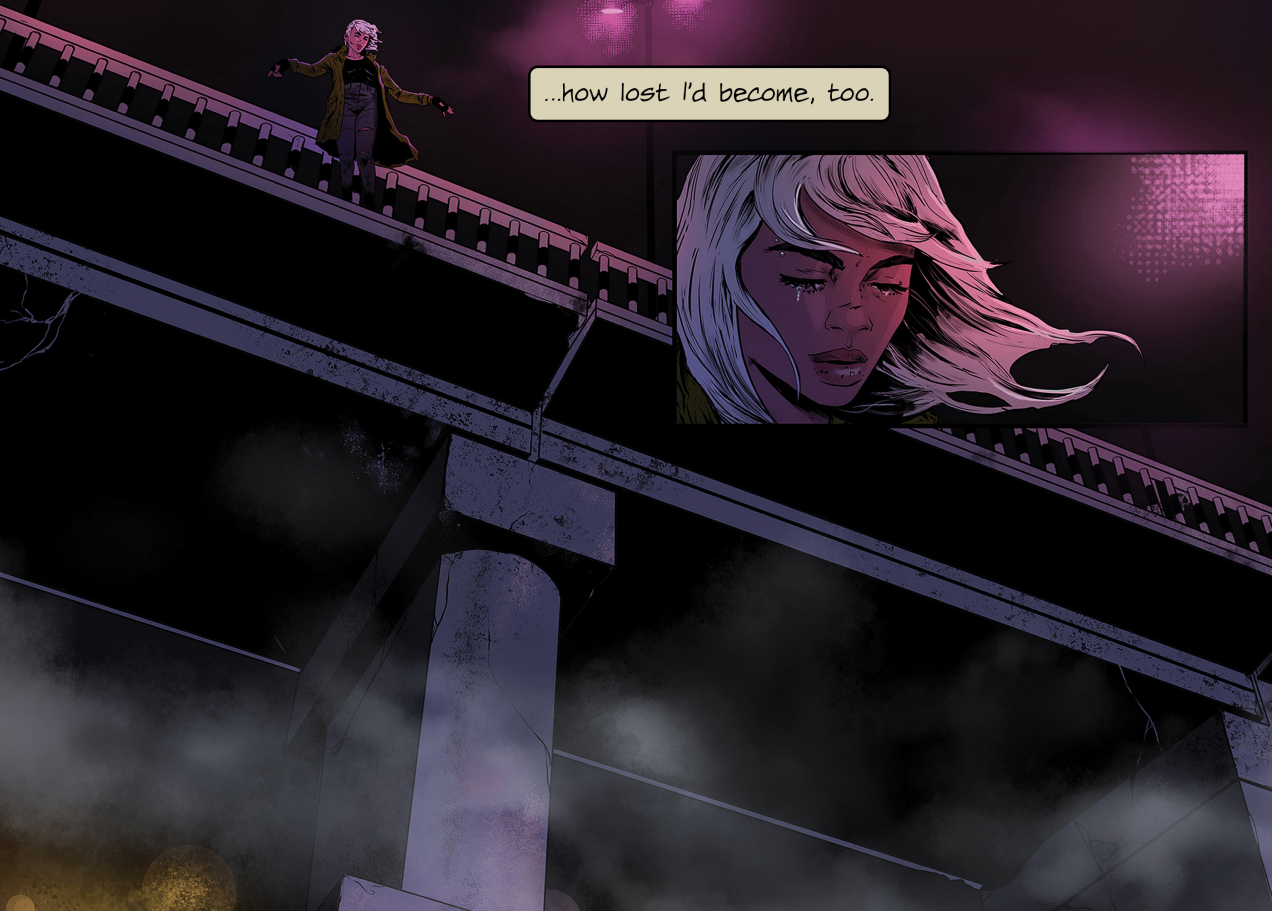

...how lost I'd become, too.





I didn't know what a homeless person was when he disappeared.

Now I was one.

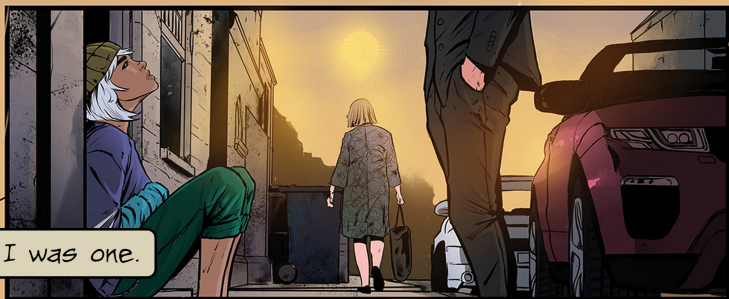

I wanted to be a scientist when I was younger...



...but with new situations come new skills.



And increased fitness.

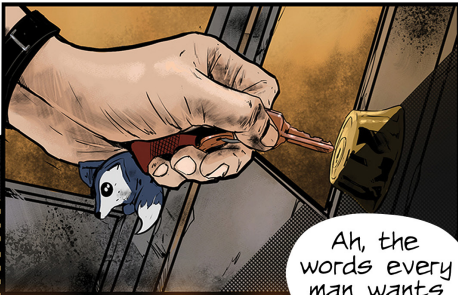
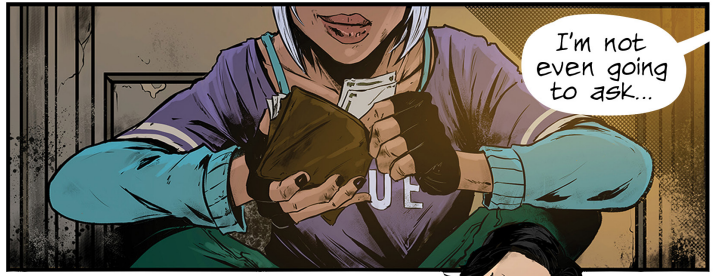

Ah, the words every man wants to hear.





Jim's a good man.



Too good.



People will walk all over him...



...if he's not careful.



The thought of that makes me hurt.



Still busy.

I've got something for you.

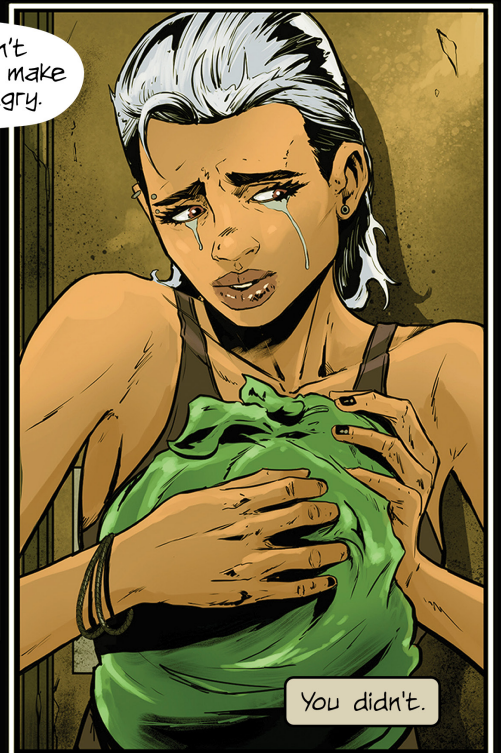
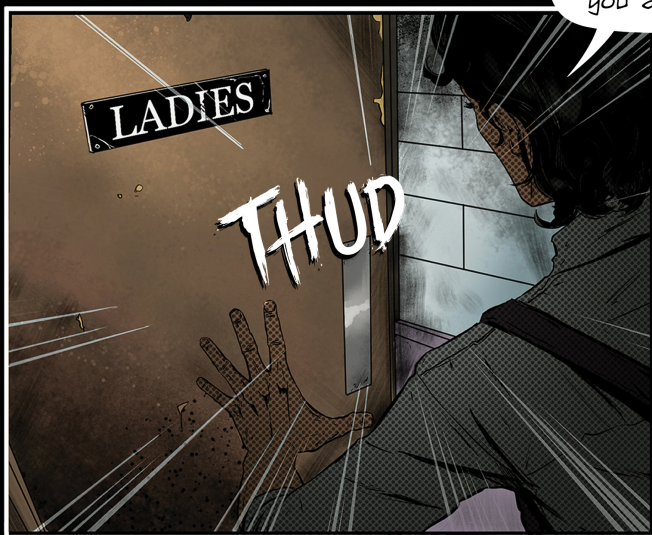

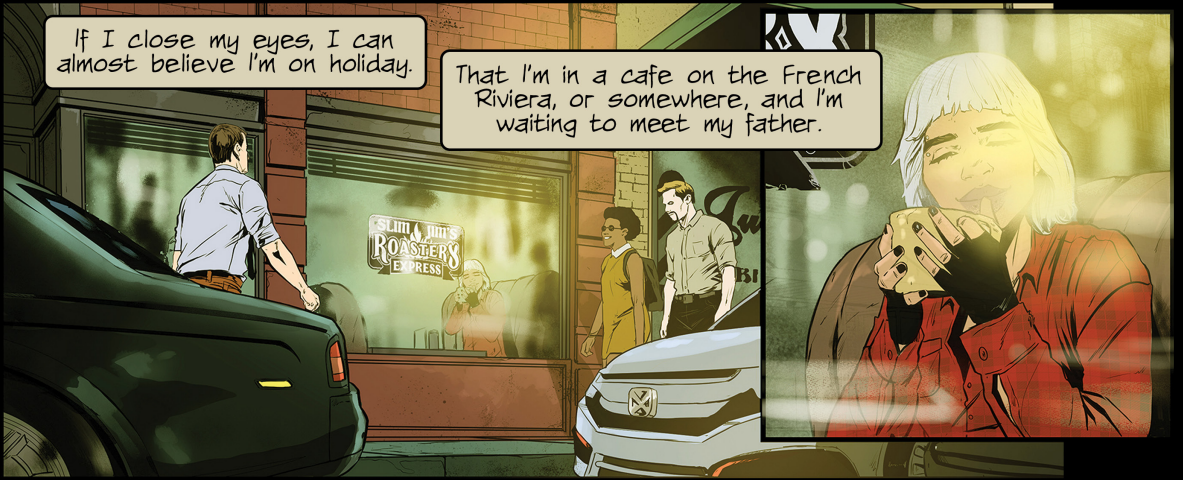

If I close my eyes, I can almost believe I'm on holiday.

That I'm in a cafe on the French Riviera, or somewhere, and I'm waiting to meet my father.

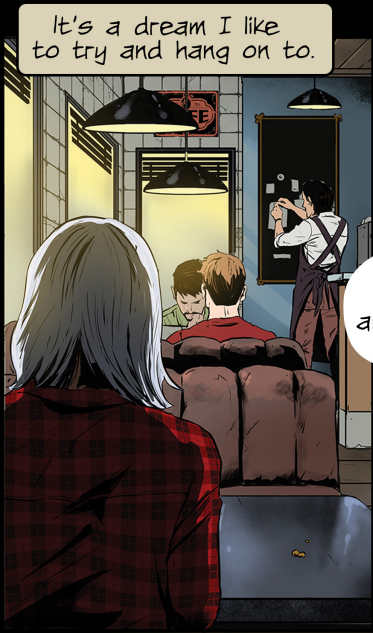

It's a dream I like to try and hang on to.

Here, I saw this and thought of you.



I was daydreaming.



Skills fair? What? So, I can build myself a house?

So you can learn a skill.



Not interested.

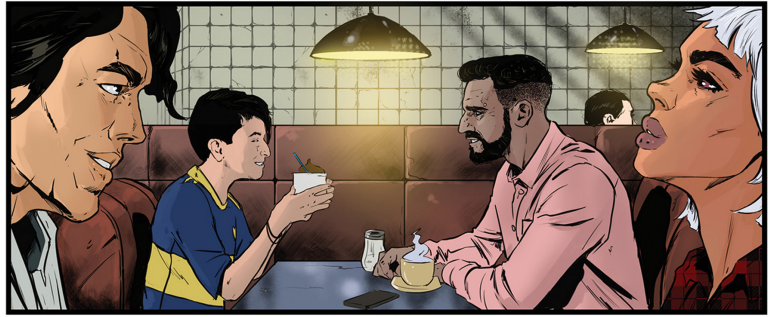



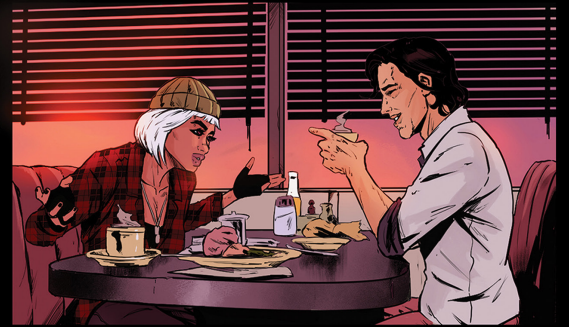



JIM!

Jim died of an aneurysm.



He didn't suffer.



He didn't...



I wanted to give up. Or worse.

LAUN

But I knew his memory
was never going to let me.

Engineer
Diploma
Distinction

XXX

Engineer
Diploma
Distinction

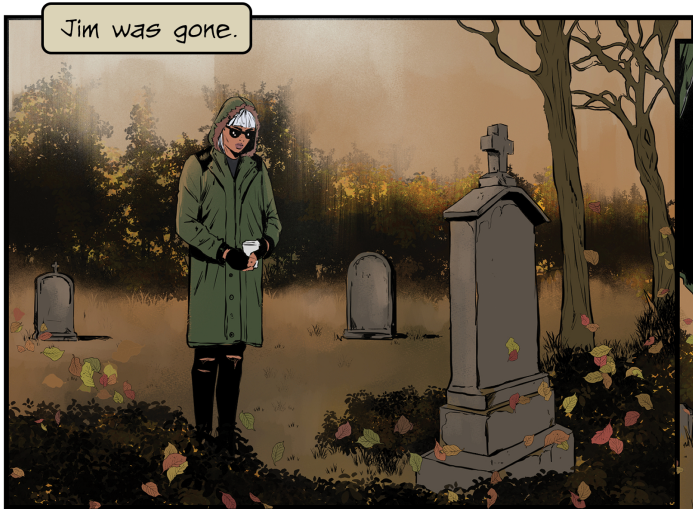

Jim was gone.



Irretrievable.

But my father...



He was someone I could find.



Or at least try.



I knew where to start.

I'd overheard him once talking about the Antarctic.



And there really weren't a lot of places to choose from.

Fossil Blupr

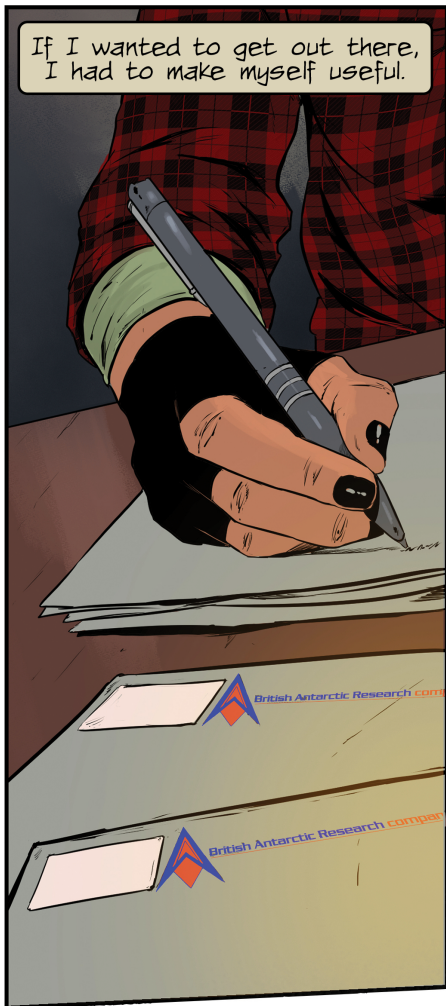

Smith-Petersen Research Station, Antarctica.

Sometimes, when you look for one thing, you find another. That's what my dad used to say.

At least, I think he said it. It's been so long now.

Looks like the new engineer's arrived.

Good. We needed the extra vehicle.

I wonder what he'd think if he knew I was here.

I'm glad they can't see the size of the grin on my face.

They might wonder why I wanted to be out here so much.

And if they knew that, they might have never let me come.

A 50 min
B 80 min

REC
45k
CHG 88888888



Hi, I'm Hannah.

Should have been here yesterday.



They said they'd let you know...

They didn't. Don't rely on others. Not out here.



Jeez, did I piss you off already?

I like punctuality.



I like courtesy.



Follow me. Bring your coat.



We have a job to do.

Already?



It's the Antarctic, you must fix things quickly.

What's his problem?

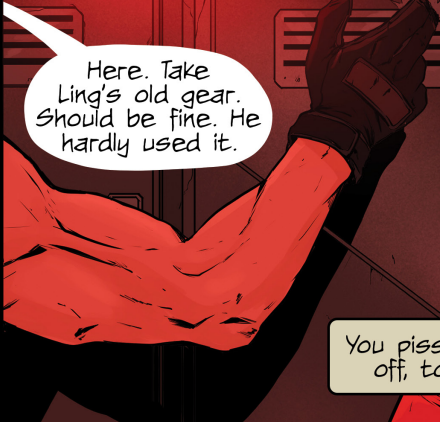

Here. Take Ling's old gear. Should be fine. He hardly used it.

You piss Ling off, too?



What's the job?

Faulty antenna out in the field. Not too far.



You ever work in these temperatures?

Nothing quite this cold...



Che cavolo! Un novizio!

THUD



Novice?

I'll give him novice.

I worked hard to get here.

Studied shit this
guy's never heard of.

Why aren't there more men like
Jim? Christ, I miss him so much.

There's your
problem.

Lucky
guess.

What
the hell?!



You see that flash?

You get all sorts going on out here. Just ignore it.



Something's not right.

Shouldn't this room be manned at all times?



Yes.



This can't be right.

What?

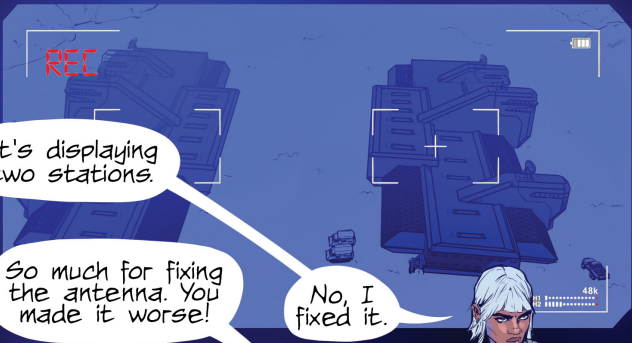

It's displaying two stations.

So much for fixing the antenna. You made it worse!

No, I fixed it.



Where are you going?



Get back in here, Curtis. That's an order.

NO!

Strange, doesn't feel as cold as earlier.



I'll have you fired, if you don't die first.

I won't let myself die. I've got a job to do out here.



Find my father, or find out what happened to him.

There's something there.



Not something, someone.

Sometimes, when you look for one thing, you find another. That's what he said.



Holy shit.



Dr. Hannah Curtis

I don't think this is what he meant.



Hello, Hannah. We need to talk about Father.

NEXT ISSUE: LOCKED DOWN



ANTARCTICA

BIRKS
ROBERTS
WHITE

WILLI
ROBERTS

SIMON BIRKS

...is an award-winning writer of comics, novels and films based in Linlithgow, Scotland. In 2015, he co-founded Blue Fox Comics with Marielle Bouleau and together they have successfully funded over 50 comic book Kickstarter campaigns. Also, Michael Palin once called a film he co-wrote 'very silly', and that's good enough for him.



WILLI ROBERTS

...is a comic book artist based in Mar Del Plata, Argentina, who started working in comics as a penciler, inker, colourist and graphic designer in 2010, drawing for publishers in the USA, Australia, Italy and the UK. His titles include *The Dark*, *Clodagh*, *The Blood Below* and indie-game tie-in comic *Remothered*.



LYNDON WHITE

...is an illustrator, writer and comic book artist. His works have been published by Image, Top Cow and Blue Fox Comics. His acclaimed graphic novels *Sparks and the Fallen Star* and *Candles* are fantasy favourites.

Over his career, Lyndon has successfully worked as part of over 40 Kickstarter campaigns, been supported by Arts Council England and worked with clients such as Twitch and the Historic Royal Palaces.

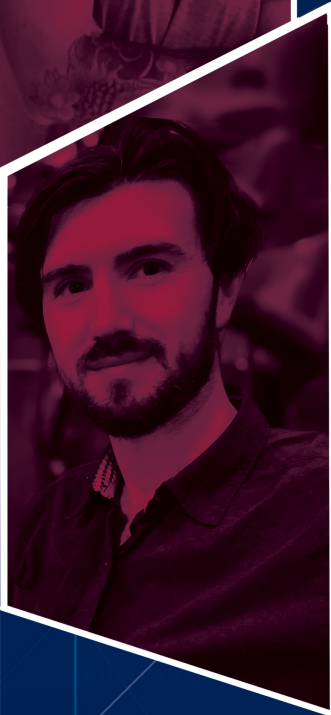



HANNAH

EAST

TARCTICA



GALLERY



JIM



CHARACTER DESIGNS



MATTEO



HIRSCH

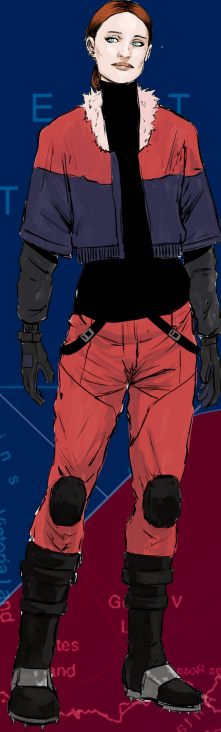
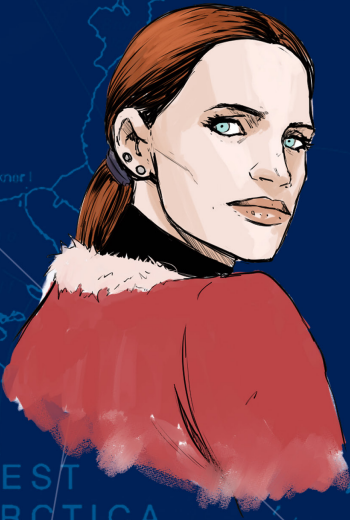

CAMPBELL



GALLERY

VEHICLE
DESIGNS

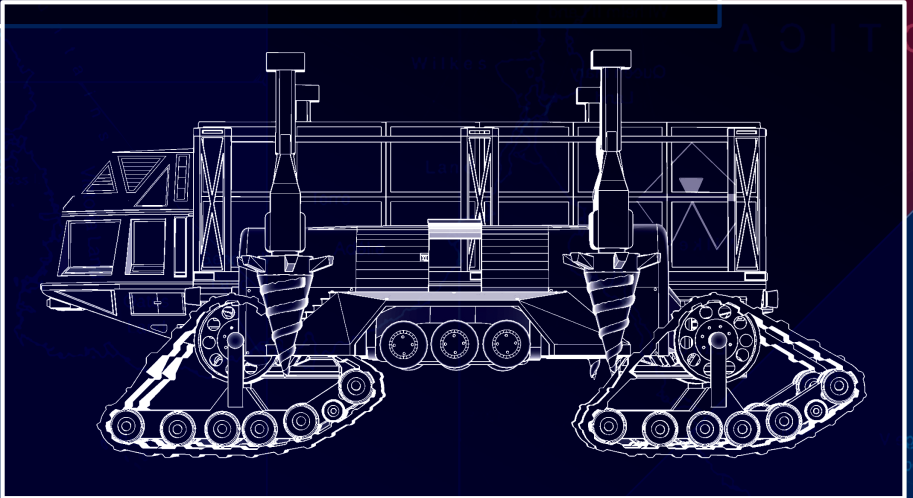
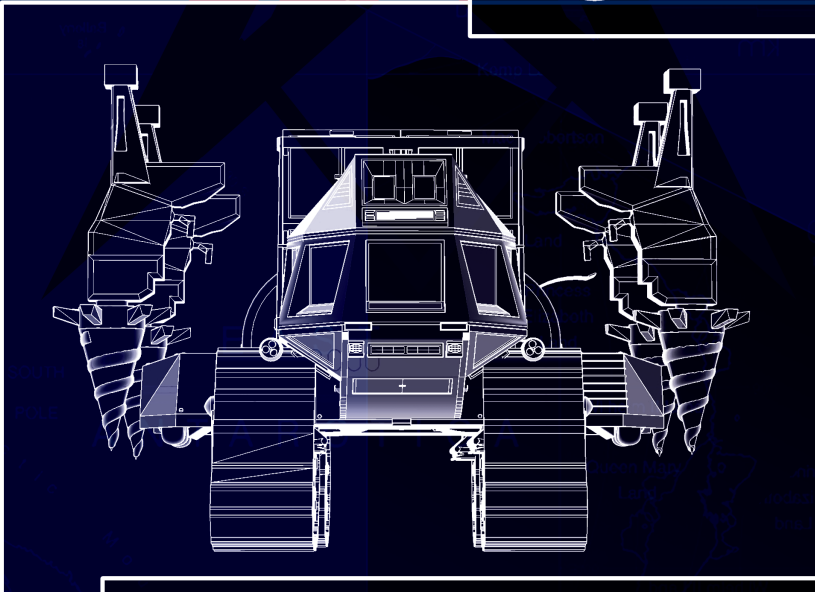
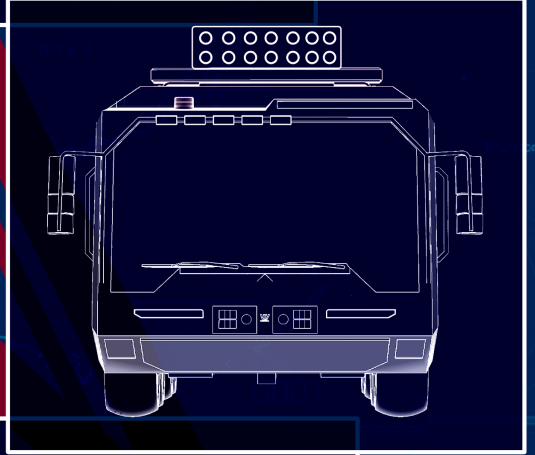
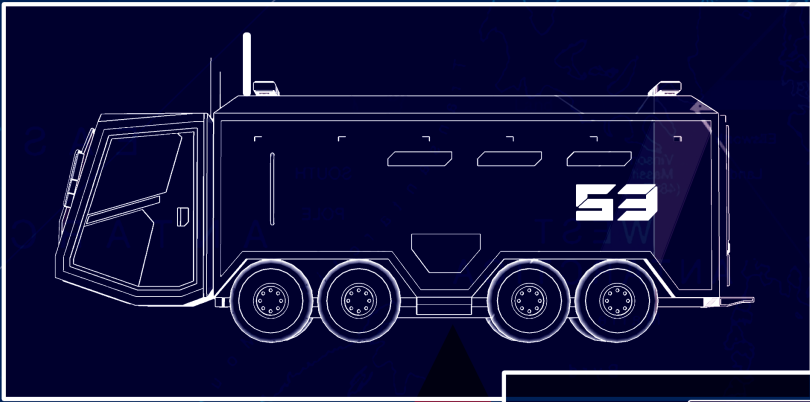

The ultimate *Aphrodite IX* collection,

featuring over 500 pages collecting all of the *Aphrodite IX* books to date.

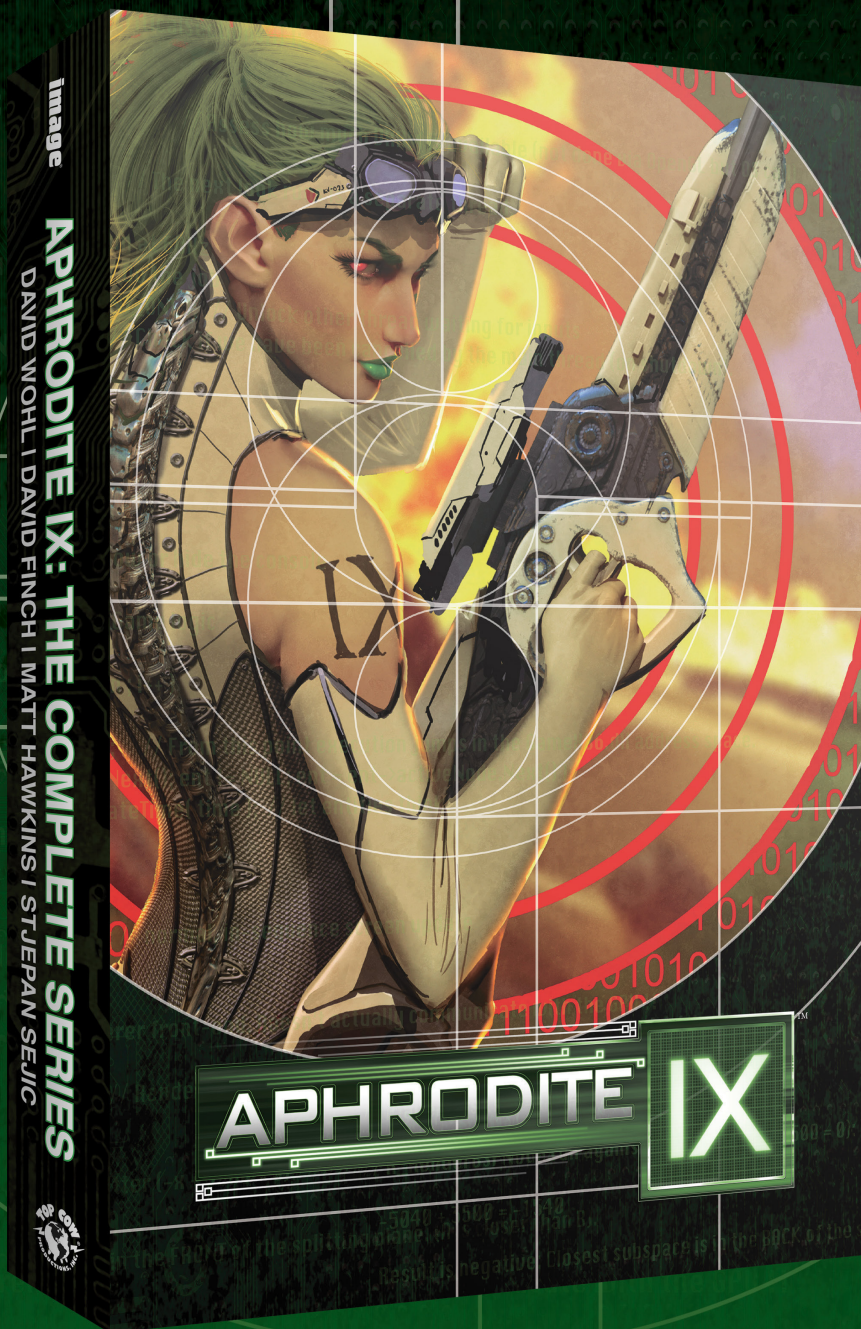

Taking place hundreds of years after a cataclysmic event scorched the surface, Earth and its inhabitants have been forever altered and new landscapes and political struggles have taken hold between two distinct factions fighting for control. Aphrodite IX is both anachronism and advanced technology in a world that she no longer recognizes.

Collects *Aphrodite IX Rebirth* #1-11, *Aphrodite IX/Cyberforce*, *Aphrodite IX: Hidden Files* & *Aphrodite IX: Time Out of Mind* #0-4.

Available Now. Diamond Order Code: FEB150517 • ISBN: 978-1-6321-5368-5

Aphrodite IX TM and © Top Cow Productions, Inc. All Rights Reserved. • Topcow.com • Follow @TopCow   

